

RLSCA-50K Rocker Column, Stainless Steel Welded-seal, IP67, NTEP 1:10,000 Class IIIIL Multiple Cell

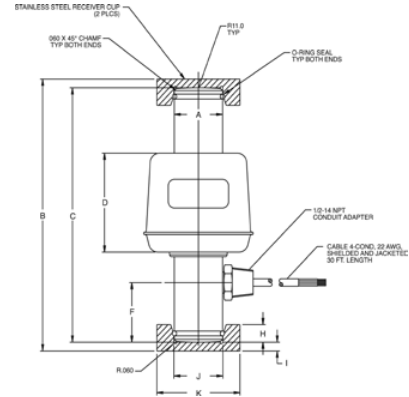

Picture is a representation of actual product



SPECIFICATIONS

Full Scale Output:
2 mv/V nominal

Output Resistance:
1050 ohms +/- 10

Input Resistance:
1100

Material/Finish:
Stainless Steel

Temperature:
Compensated range
14°F to 104°F/-10°C to 40°C

Safe Overload:
150% Full scale

Rated Excitation:
10V DC (15V maximum)

Combined Error:
.025% Full scale

Non-repeatability:
.01% Full scale

Insulation Resistance:
1000 megohms

Seal Type:
Welded-seal, IP67

Cable Length:
30 ft/9 m

Cable Diameter:
.200 polyurethane jacket

Cable Color Code:
Green..... + Excitation
Black..... - Excitation
White..... - Signal
Red..... + Signal

Warranty:
Two-year limited warranty



DIMENSIONS

RATED CAPACITY	A	B	C	D	F	H	I	J	K
lb/inches									
50,000	1.46	7.75	7.25	2.82	1.70	.50	.25	1.48	2.50
kg/mm									
22,679.6	37.0	196.8	184.1	71.6	43.1	12.7	6.35	37.5	63.5

ORDER INFORMATION

LOAD RATING	PART #	PRICE
*50,000 lb (22,679.6 kg)	68918	Consult
Replacement load cup set upper and lower included	85433	Consult
Replacement O-rings	92988	Consult

*Load cell supplied with load cups

INTERCHANGEABLE PRODUCTS

MANUFACTURER	MODEL
Cardinal®	SCA-50K

RICE LAKE WEIGHING SYSTEMS

